

## ACTOM ELECTRICAL MOTORS

### ML1: Single Phase Motor

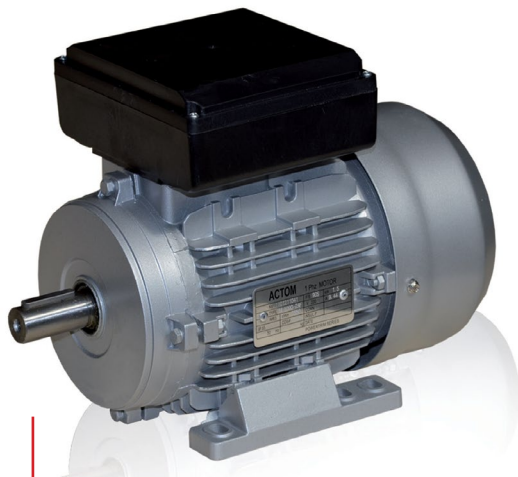

#### Specifications:

Please Download the ACTOM Brochure Attached for all of the Product Specifications

#### General Data:

##### Product Information:

<b>Low Voltage</b>	TEFC aluminium frame single phase motors
<b>Ratings</b>	From 0,25kW to 2,2kW at 230V
<b>Product</b>	Capacitor start and capacitor run product
<b>Enclosures</b>	IP55 Enclosures and Class F Insulation

##### Typical

##### Application:

<b>Application</b>	Please see attached
<b>Designed for</b>	brochure

# ACTOM ALUMINIUM SINGLE-PHASE T.E.F.C. INDUCTION MOTOR.

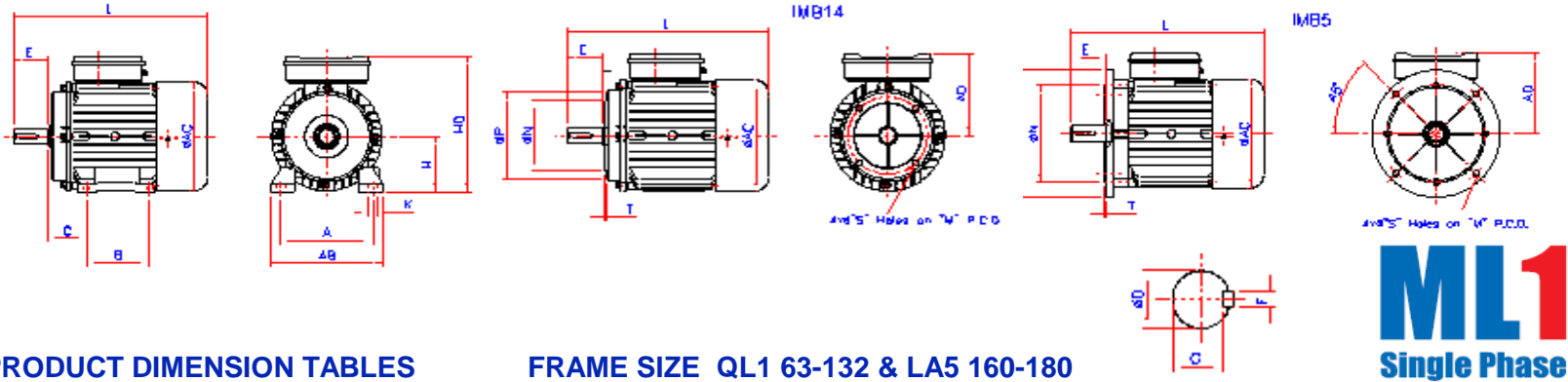

## PRODUCT DIMENSION TABLES

## FRAME SIZE QL1 63-132 & LA5 160-180

FRAME SIZE	KEY B5 DIMENSIONS										IMB14					IMB5					GENERAL FRAME DIMENSIONS				
	POLE	A	B	C	D	E	F	G	H	K	M	N	P	S	T	M	N	P	S	T	AB	AC	AD	HD	L
71	2-8	112	90	45	14	30	5	11	71	7	85	70	105	M6	2,5	130	110	160	10	2,5	145	145	125	210	255
80	2-8	125	100	50	19	40	6	15,5	80	10	100	80	120	M6	3,0	165	130	200	12	3,0	160	165	135	240	295
90S	2-8	140	100	56	24	50	8	20	90	10	115	95	140	M8	3,0	165	130	200	12	3,0	180	185	145	270	335
90L	2-8	140	125	56	24	50	8	20	90	10	115	95	140	M8	3,0	165	130	200	12	3,0	180	185	145	270	360
100L	2-8	160	140	63	28	60	8	24	100	12	130	110	160	M8	3,5	215	180	250	15	3,5	205	215	170	280	380
112	2-8	190	140	70	28	60	8	24	112	12	130	110	160	M8	3,5	215	180	250	15	3,5	222	228	180	292	425

Values indicated are subject to change without prior notice. For installation and construction contact ACTOM Electrical Machines for certified dimensions.

## PRODUCT PERFORMANCE DATA

Rated Output kW	Frame Size IEC	Rated Speed RPM	No of Poles	Rated Voltage V	Rated Current A	Efficiency %	Power Factor	Locked Rotor Torque p.u.	Breakdown Torque p.u.	Locked Rotor Current p.u.	Motor Mass kg aprox	Frame type available	Hz
0,37	70	2800	2	220	2.73	67	0.92	2.3	1.8	16	7	B3, B14 & B5	50
0,55	70	2800	2	220	3.88	70	0.92	2.5	1.8	21	8	B3, B14 & B5	50
0,75	80	2800	2	220	5.15	72	0.92	2.5	1.8	30	8.5	B3, B14 & B5	50
1,1	80	2800	2	220	7.02	75	0.95	2.5	1.8	40	9.5	B3, B14 & B5	50
1,5	90S	2800	2	220	9.44	76	0.95	2.5	1.8	55	12.5	B3, B14 & B5	50
2,2	90L	2800	2	220	13.67	77	0.95	2.5	1.8	80	14	B3, B14 & B5	50
0,25	70	1400	4	220	1.99	62	0.92	2.5	1.8	12	6.9	B3, B14 & B5	50
0,37	70	1400	4	220	2.81	65	0.92	2.5	1.8	16	8.1	B3, B14 & B5	50
0,55	80	1400	4	220	4.00	68	0.92	2.5	1.8	21	8.9	B3, B14 & B5	50
0,75	80	1400	4	220	5.22	71	0.92	2.5	1.8	30	9.6	B3, B14 & B5	50
1,1	90S	1400	4	220	7.20	73	0.95	2.5	1.8	40	13	B3, B14 & B5	50
1,5	90L	1400	4	220	9.57	75	0.95	2.5	1.8	55	16	B3, B14 & B5	50
2,2	100L	1400	4	220	13.90	76	0.95	2.5	1.8	80	23	B3, B14 & B5	50

All values are subject to change without prior notice. For guaranteed values, please contact an ACTOM ELECTRICAL MACHINES outlet. All values are subject to IEC tolerances.

## Complete your Project:

Please select the items you require and we will be in touch

### Cables and Wires:

Indoor  
Outdoor  
General  
Other  
Let an ACTOM  
Specialist Contact you

### Lighting:

Indoor  
Outdoor  
General  
Other  
Let an ACTOM  
Specialist Contact you

### Transformers (Distribution):

Indoor  
Outdoor  
General  
Other  
Let an ACTOM  
Specialist Contact you

### Accessories:

Indoor  
Outdoor  
General  
Other  
Let an ACTOM  
Specialist Contact you

### Specific Information:

Address: 4 Branch Road, Germiston 1401, P.O. Box 678, Germiston 1400

## For more Information on this Product Please Send us the Following

### Product Information:

Product Name:

Quantity:

Project Name:

Date the Product is required:

### Your Contact Information:

Name and Surname:

Company:

Email:

Phone Number:

Province:

## Thank You

### For having a Look at this Product

Please send this PDF back to us with all your Information

Scan the QR Code to visit our Website:

